

MSPL & MSAL User's Manual / Mounting Template

Up to 120 lbs / 54 kg

Included Mounting Hardware

1. Mount (MSPL or MSAL) (x1)
2. M5 x 10, 15 & 25 mm bolts (x4)
3. M6 x 10, 15 & 25 mm bolts (x4)
4. M8 x 10, 15 & 25 mm bolts (x4)
5. Rectangular washers (x4)
6. Concrete anchors (x4)
7. Round washers (x4)
8. 5/16" lag bolts (x4)
9. Mounting template (x1)
10. Allen key (x2)
11. Wrench (x1)

Included Mounting Hardware (For Curved LCD/LED TV and SAMSUNG TV)

1. M8 x 30 bolts (x4)
2. M8x 50 bolts (x4)
3. Ø15 x Ø8xØ5 mm spacer (x8)
4. Ø15 x Ø6xØ15 mm spacer (x8)

You Will Need

- | | |
|-----------------|---------------------------|
| A. Bubble level | E. 3/16" (wood) or |
| B. Stud finder | 1/2" (concrete) drill bit |
| C. Marker | F. Hammer |
| D. Drill | G. Wrench |

*MSPL used in diagrams, steps also apply to MSAL

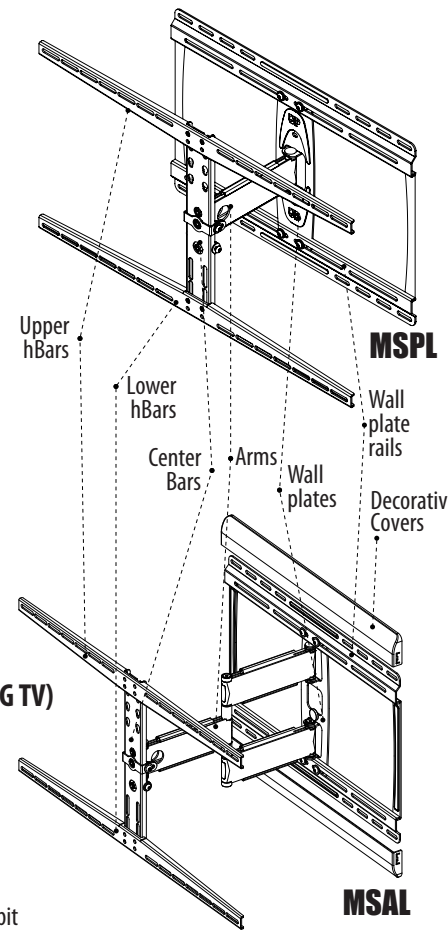

Disclaimer

Monster Mounts intends to make this manual accurate and complete, however, Monster Mounts makes no claim that the information contained herein covers all details, conditions or variations, nor does it provide for every possible contingency in connection with the installation or use of this product. The information contained in this document is subject to change without notice or obligation of any kind. Monster Mounts makes no representation of warranty, expressed or implied, regarding the information contained herein. Monster Mounts assumes no responsibility for accuracy, completeness or sufficiency of the information contained in this document.

Warnings & Cautions

IT IS HIGHLY RECOMMENDED THAT THIS PRODUCT BE INSTALLED BY A PROFESSIONAL.

PLEASE REVIEW THIS INSTRUCTION MANUAL COMPLETELY BEFORE STARTING THE INSTALLATION PROCESS.

WARNING: A WARNING alerts you to the possibility of serious injury or death if you do not follow the instructions.

CAUTION: A CAUTION alerts you to the possibility of damage or destruction of equipment if you do not follow the corresponding instruction.

WARNING: Improper installation can result in serious personal injury! Make sure that the structural members can support a weight factor five times the total weight of the equipment. If not, reinforce the structure before starting the installation.

WARNING: Be aware also of the potential for personal injury or damage to the unit if it is not adequately mounted.

WARNING: The installer is responsible for verifying that the wall or ceiling to which the mount is anchored will safely support the combined load of all attached components or other equipment.

WARNING: The weight of the display placed on the mount must not exceed the maximum load capacity of the mounts.

WARNING: Watch for pinch points. Do not put your fingers between movable parts.

WARNING: Make sure the mount and brackets are correctly oriented.

CAUTION: Check the unit for shipping damage before you begin the installation.

For more information, visit:
www.monstermounts.com

© Monster® Mounts



AUM179 v1.0



1. Adjust Wall Plate Location

***Important Note**
Due to MSPL's nature, the center of your TV will only be on the center of the wall place when the mount is fully extended; otherwise it will be offset to the right or left up to 8.6" (218 mm) when flat to the wall. MSAL will fold back to the center when flat to the wall (no offset).

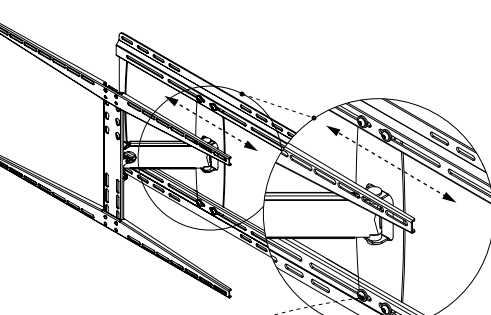
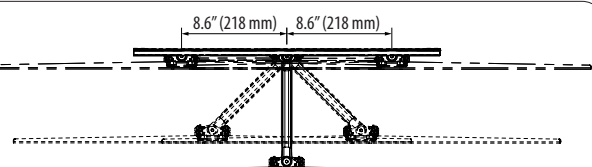

- 1.1 Loosen bolts and position the wall plate in the desired sliding slots of wall plate rails. You may have to remove the bolts (x4) and washers (x4). Once you have bolted the rails to the wall, it will be difficult to slide the wall plate sideways.

*Make sure you understand the important note.

2a. Drywall Installation

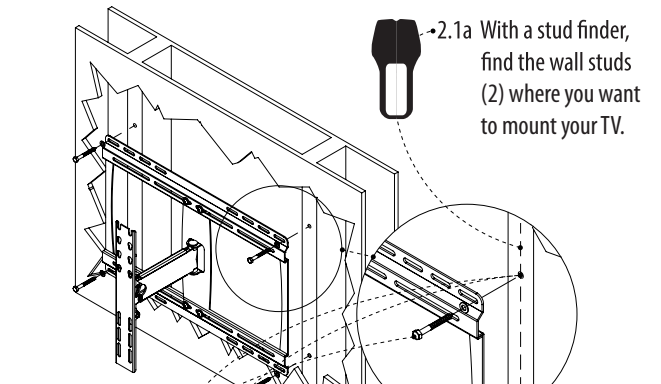

- 2.1a With a stud finder, find the wall studs (2) where you want to mount your TV.
- 2.2a Mark the center of the studs. Using the provided mounting template** mark the 4 holes where the wall plate will be mounted. **Make sure it's leveled.**

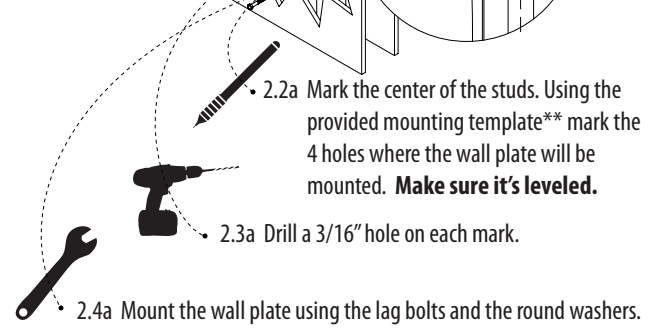

- 2.3a Drill a 3/16" hole on each mark.
- 2.4a Mount the wall plate using the lag bolts and the round washers. **Do not overtighten.**

2b. Concrete Installation

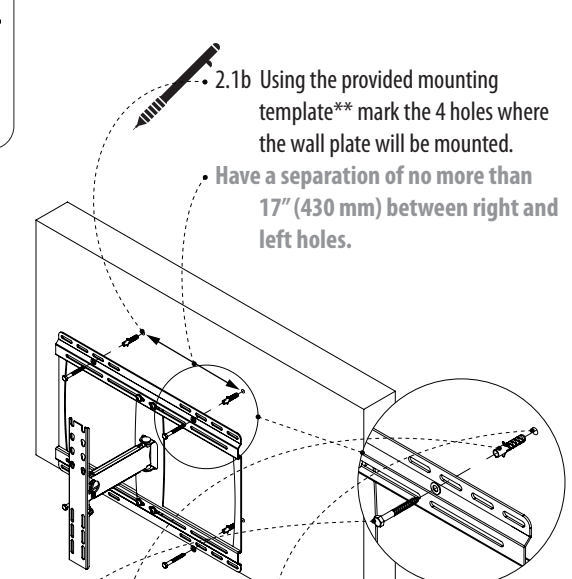

- 2.1b Using the provided mounting template** mark the 4 holes where the wall plate will be mounted.
- Have a separation of no more than 17" (430 mm) between right and left holes.
- 2.2b Drill a 1/2" hole with the same depth of the anchor on each mark.

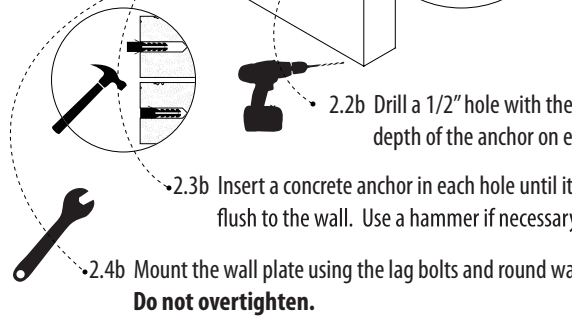

- 2.3b Insert a concrete anchor in each hole until it's flush to the wall. Use a hammer if necessary.
- 2.4b Mount the wall plate using the lag bolts and round washers. **Do not overtighten.**

3a. Fix hBars to TV

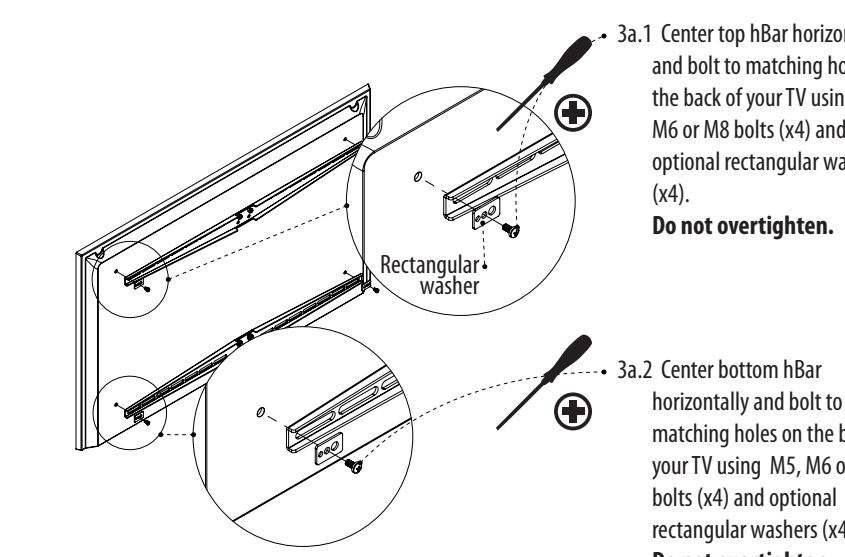
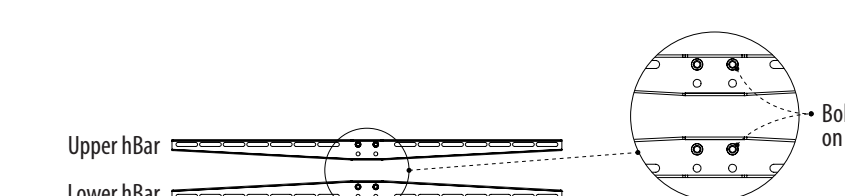

- 3a.1 Center top hBar horizontally and bolt to matching holes on the back of your TV using M5, M6 or M8 bolts (x4) and optional rectangular washers (x4). **Do not overtighten.**
- 3a.2 Center bottom hBar horizontally and bolt to matching holes on the back of your TV using M5, M6 or M8 bolts (x4) and optional rectangular washers (x4). **Do not overtighten.**

3b. Fix hBars to TV (For Curved LCD/LED TV and SAMSUNG TV)

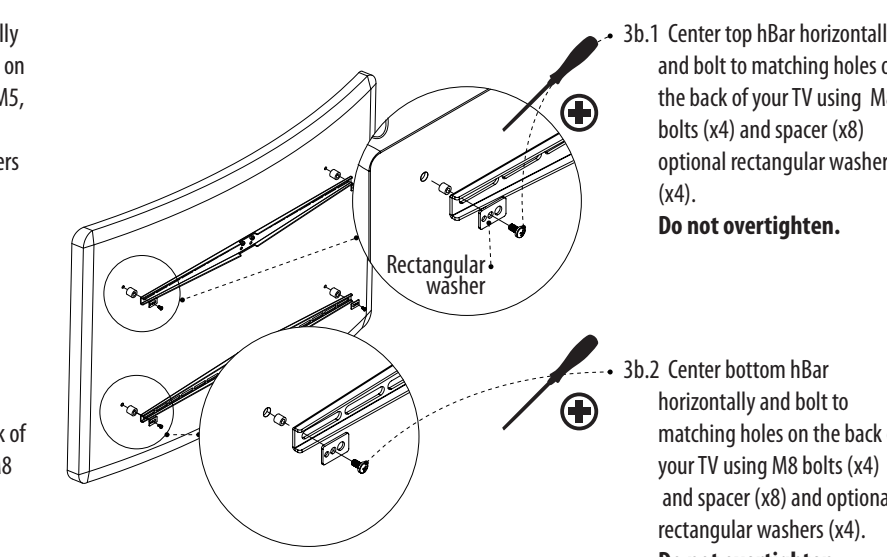
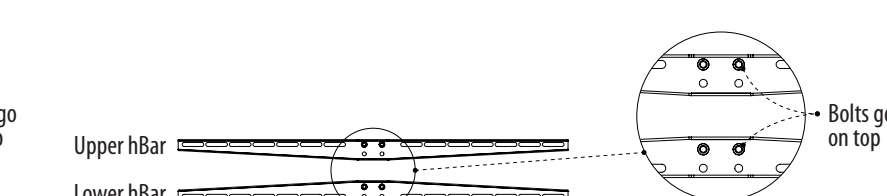

- 3b.1 Center top hBar horizontally and bolt to matching holes on the back of your TV using M8 bolts (x4) and spacer (x8) optional rectangular washers (x4). **Do not overtighten.**
- 3b.2 Center bottom hBar horizontally and bolt to matching holes on the back of your TV using M8 bolts (x4) and spacer (x8) and optional rectangular washers (x4). **Do not overtighten.**

4. Hang TV from Arm

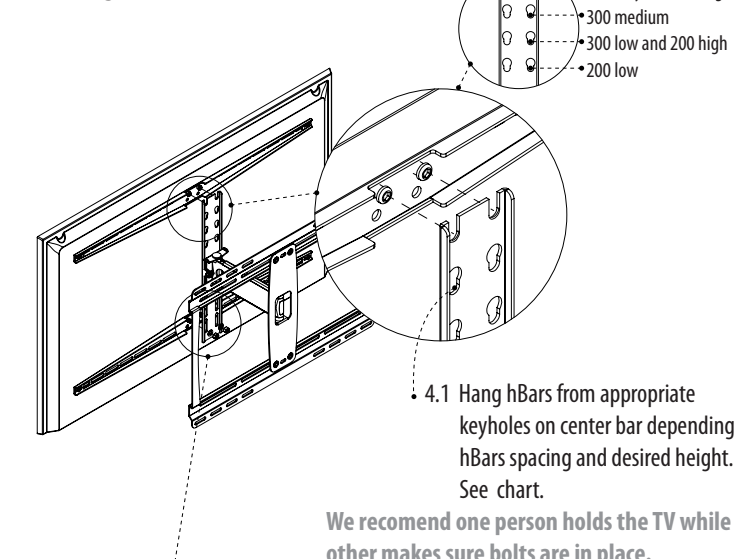

- 4.1 Hang hBars from appropriate keyholes on center bar depending on hBars spacing and desired height. See chart.
- 4.2 Fix lower hBar with allen bolt (x2). **Do not over tighten.**

We recommend one person holds the TV while other makes sure bolts are in place.

5. Conceal Cables

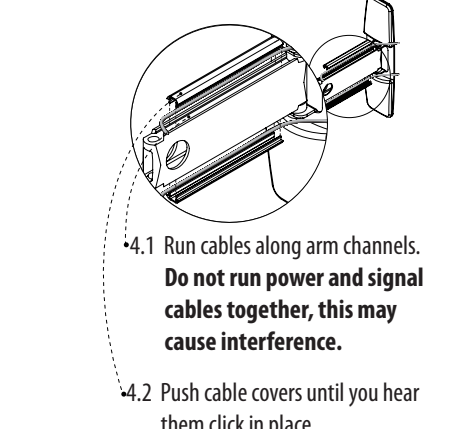

- 4.1 Run cables along arm channels. **Do not run power and signal cables together, this may cause interference.**
- 4.2 Push cable covers until you hear them click in place.

Tilting

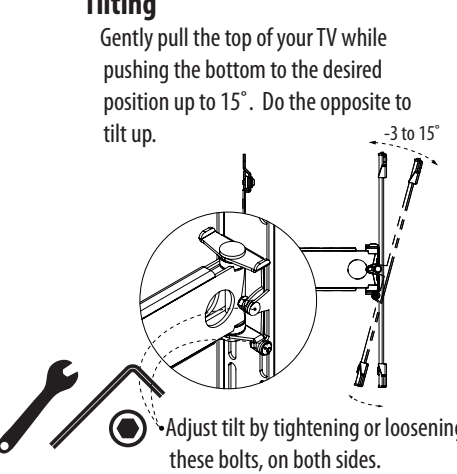

Gently pull the top of your TV while pushing the bottom to the desired position up to 15°. Do the opposite to tilt up.

Adjust tilt by tightening or loosening these bolts, on both sides.

Horizontal Adjustment

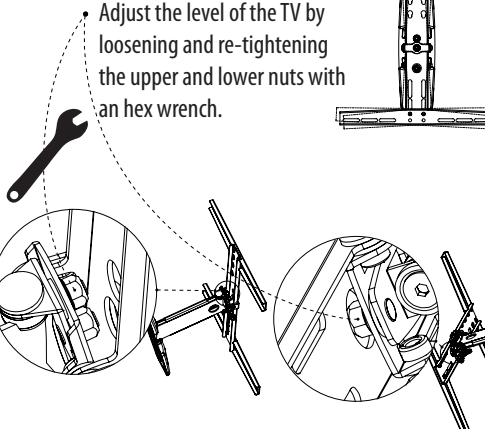

Adjust the level of the TV by loosening and re-tightening the upper and lower nuts with an hex wrench.

Panning

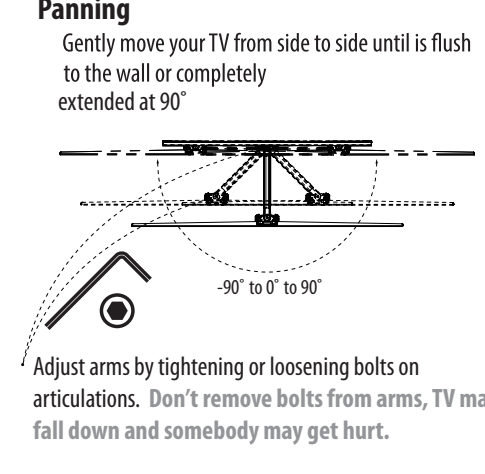

Gently move your TV from side to side until it is flush to the wall or completely extended at 90°.

Adjust arms by tightening or loosening bolts on articulations. Don't remove bolts from arms, TV may fall down and somebody may get hurt.